

SL50-ACC10 Instruction Sheet

Signatrol Ltd,
105 Church Street
Tewkesbury
Gloucestershire
GL20 5AB
Telephone: 01684 299 399
Fax: 01684 299 375
Email: support@signatrol.com

Introduction

All our SL50 series button data loggers are sealed to IP55 which means that they are "Protected against ingress of dust and protected against low-pressure jets of water". This means that occasional liquid exposure is no problem but if the unit is to be immersed in a liquid, especially where there are changes in temperature, the device needs the extra protection of an additional enclosure. Any secondary enclosure will increase the response time but the SL50-ACC10 has been designed to minimise this effect.

The enclosure consists of an 'O' ring protected aluminium alloy sleeve into which the button is inserted and a stainless steel bleed screw to allow the internal air to escape for insertion and removal. The Dural sleeve is hard anodised in bright blue making it easy to identify when it needs to be retrieved and is supplied fitted with an FDA approved 'O' ring making it compatible for use in food and beverage manufacturing. A convenient mounting hole is also provided in the bleed screw that enables the device to be easily attached to a retaining strap or cable.

Response Time

All devices have a response time normally expressed as its Time Constant or the time it takes for the device to reach 63% of its final value. (for a more detailed explanation visit www.signatrol.com/response-time.php). The response time in liquid for a button logger inside the SL50-ACC10 enclosure is 37 Seconds (63%).

Instructions for Use

The SL50 series logger is connected to a PC running TempIT and is issued in the normal way.

Unscrew the knurled bleed pin and coat both the point of the pin and the internal 'O' ring with a suitable lubricant that is compatible with your process. We have found that cooking oil works fine for most applications. It is important

to do this lubrication as it aids the insertion and removal process as well as ensuring an adequate seal. Push the button firmly into the enclosure such that the rear of the button is flush with the edge of the enclosure. Replace the bleed pin, ensuring it is as tight as you can make it by hand. **DO NOT USE ANY EXTERNAL GRIPS, BARS ETC AS THIS CAN DAMAGE THE SEALING FACES.** Do not attempt to use the enclosure without the pin fitted as this can result in irreparable damage to the logger. You are now ready to perform your mission.

At the end of the test clean and dry the outside of the enclosure. Unscrew the pin and insert a small screwdriver blade in the slot between the enclosure and the button rear face, twisting gently. Repeat in the opposing slot and the button should protrude from the enclosure sufficiently to enable it to be fully extracted by hand, if not repeat the process.

Specification

Material	Body	AW-2011 Grade Aluminium Alloy, Hard Anodised 25um Blue
	Pin	316 Stainless Steel
	O-Ring	FDA Food Grade EPDM. See below for more details.
Temperature Range	-40°C to +140°C -40°F to +284°F	
Response Time	37 Seconds in water	
Weight	4.5g without data logger 7.5g with data logger	

Dimensions

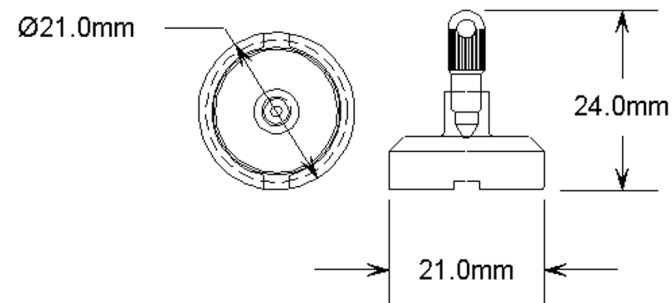

Response Time

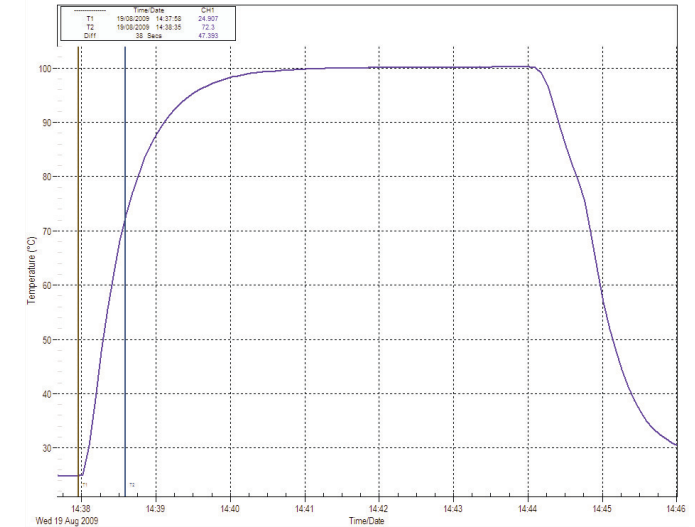

O-Ring Specification

Ethylene Propylene Elastomer EPDM Compound	
Description	Black, Ethylene Propylene Rubber EPDM, NSF 61, KTW, WRAS, OVGM approved, FDA compliant.
Temperature Range	-40 to +140°C depending on sealing medium and application.
Chemistry	Co-polymer of ethylene and propylene, or terpolymer with butadiene
Approved To	ANSI/NSF Standard 61 (Hot Applications) for potable water
Conformance To	ASTM D2000 M4CA710, A25, B35, C32, EA14, F17.
FDA Compliance	Material formulated and compliant with FDA regulations 21 CFR sect. 177.2600.
Application	Excellent resistance to water, acids and alkalis. EPDM is also highly resistant to oxygen, ozone and weathering.
Limitations	Poor resistance to oil, gasoline and hydrocarbon solvents.